

TECHNICAL SERVICE
01903 730900

AIR OPERATED FOOD GRADE PISTON PUMPS PA SERIES



**INSTRUCTIONS FOR INSTALLATION,
OPERATION AND MAINTENANCE**

INDEX

- FOREWORD**
- 1 SYMBOLS**
- 2 SAFETY WARNINGS**
- 3 GUARANTEE**
- 4 GOODS TRANSPORTATION, RECEIVING AND TRANSFERRING**
 - 4.1 Transportation
 - 4.2 Receiving
 - 4.3 Transferring
- 5 DESCRIPTION**
- 6 APPLICATIONS**
- 7 NON-PERMITTED USES**
- 8 SEALS**
 - 8.1 "T00" seal
 - 8.2 "T12-T40" seals
 - 8.3 "T13-T42" seals
 - 8.4 "T10" seal
 - 8.5 "T50" seal
- 9 INSTALLATION AND STARTING**
 - 9.1 Installation
 - 9.2 Connecting to the compressed air supply
 - 9.3 Hydraulic connection
 - 9.4 Flow adjustment
- 10 MAINTENANCE AND INSPECTION**
 - 10.1 Important !
 - 10.2 Extended stop
 - 10.3 Cleaning the pump
- 11 DISASSEMBLY**
 - 11.1 Disassembling the motor
 - 11.2 Disassembling the pump
 - 11.3 Disassembling the piston
- 12 WORKING IRREGULARITIES**
 - 12.1 The pump does not start
 - 12.2 The pump reciprocates but there is no flow
- 13 DISPOSAL OF THE PUMP**

FOREWORD

- Read the instructions carefully and keep them for future consultation.
- C.S.F. Inox S.p.A. reserves the right to make any changes to the documentation it deems necessary without being obliged to update publications that have already been issued.
- When requesting information, spare parts or assistance, always specify the pump type (*) and serial number (**) in order to ensure fast and efficient service: the complete code is given on the plate and in the purchase documents.

CSF
inox

POMPE - RACCORDERIA
Montecchio E. - ITALY
☎ 0522869911 - <http://www.csf.it>

○ Modello ○

Plate example

1 SYMBOLS

WARNING	<i>Pay great attention to the text parts indicated by this symbol.</i>
	<i>Danger:</i> <i>the non-observance of instructions can cause serious damages to persons and/or objects.</i>

2 SAFETY WARNINGS

When the pump is working the following occurs:

- Mechanical parts are moving.
- Pump body, pipelines and articulations are under internal pressure.
- Do not loosen or remove guards, fasteners or screws during operation since this may result in serious injury to personnel or damage to property.
- Watch out for leaks from the seal, the suction port or above all the discharge port when pumping hazardous or toxic liquids. Install adequate monitoring and liquid recovery systems and provide a suitable hazard notice.
- It is the user's responsibility to mark the pump as an "overheated area" or to use suitable guarding when used to pump liquids at a temperature higher than 60°C.
- The pump must not be moved during operation.
- Installation must ensure an adequate space for maintenance operations.

Before carrying out any operation which requires to disassemble the pump (inspection, cleaning, seal replacement, etc.), the following preliminary operations have to be carried out:

- close the compressed air inlet tap and disconnect the supply pipe to the motor;
- close valves on suction and outlet pipelines, in order to avoid the risk of inundation;
- use adequate protections for hands and face, if the pump contains liquids which are injurious to health (for example acids, solvents, etc.);
- consider if the liquid which flows out of the pump when disassembling is dangerous and arrange for adequate safety measures.



3 GUARANTEE

All products manufactured by C.S.F. Inox are guaranteed to the purchaser, for one year from the date of purchase, against hidden defects in materials or manufacture, providing that they are installed and used according to instructions and recommendations of the manufacturer. Excluded from the guarantee other than distinctive wear and tear are repairs to damage caused by improper use, abrasion, corrosion, negligence, defect of installation, non-observance of inspection and maintenance, use of non-genuine spare parts, cause of accident or fortuity and from any action carried out by the purchaser not according to the normal instructions of the manufacturer.

WARNING Before returning to C.S.F. Inox S.p.A. any item to be substituted or repaired under guarantee, inform about the problem the Customer Assistance Office and follow instructions of the manufacturer. Any item must be properly packed in order to avoid damages during the transferring and **a technical report explaining the fault occurred, must accompany the returned item/s.**

Any item with a presumed fault should be returned to C.S.F. Inox S.p.A. with shipment costs at purchaser's charge, unless different agreements are given.

C.S.F. Inox S.p.A. will examine, repair and/or replace the returned piece and then send it back to the purchaser on ex-works basis. Should the piece be found under warranty, no further costs will be debit the purchaser. If, on the contrary, the fault is not found under warranty, all necessary reparations and replacements will be charged at normal cost to the purchaser. Commercial parts incorporated in C.S.F. products are guaranteed by their corresponding manufacturers.

4 GOODS TRANSPORTATION, RECEIVING AND TRANSFERRING

4.1 TRANSPORTATION

The packings of all pumps manufactured by C.S.F. Inox - S.p.A. are defined when placing the order. Unless prior arrangements are given, goods will be packed only for transit conditions and not for long-term storage; in case it should be necessary to store the pumps outside, you are requested to cover the pumps appropriately in order to protect the air-motor parts from rain, dust, humidity etc.

4.2 RECEIVING

WARNING By goods receiving, the wholeness of packing must be verified, in order to identify possible damages to the content occurred during transferring and to claim them immediately to the carrier. Should any damage be ascertained, the following procedure must be observed:

- collect the goods with reservation;
- take the necessary pictures showing the damages;
- notify the suffered damages, by registered airmail, to the carrier by sending at the same time the pictures taken to show the damaged pieces.

4.3 TRANSFERRING



Carry the packed pumps as close as possible to the place of installation by means of appropriate lifting devices and unpack them.

During this operation take care, as unsteady parts could fall down.

The material used for packing (wood, paper, cellophane, etc.) should be properly got rid, according to the corresponding rules in force in receiver's country.

After unpacking the pump, use special lifting belts and move the pump-motor-set to the place of installation.

PA 20-30A

PA 50-100AM

5 DESCRIPTION

The food grade PA series pumps are operated pneumatically by a double-acting piston. They are designed for professional use and are manufactured in the version for food grade applications.

They consist of a compressed air motor, central casing, the cylinder in which the pumping piston runs and the suction port with stop valve.

The pump and motor are coupled by means of a bayonet-type coupling and clamped, likewise for the cylinder, by means of quick-release clamps.

Note: For PA20A and PA30A models the pump and motor are coupled by screwing.



6 APPLICATIONS

These pumps are designed to meet the widest range of requirements for the handling of liquids, including those with extremely high viscosity.

They are used to transfer liquids from one container to another, for feeding, spraying, for circulation systems and applications requiring an adjustable flow rate. With the compressed air motor they are also suitable for dangerous and hazardous environments (explosion proof).

7 NON-PERMITTED USES

WARNING If the air operated pumps are used for flammable and/or explosive products, always check that the pressure to be generated by the pump is lower than the product's self-combustion level.

8 SEALS

There are different types of seals.

The choice of seal design and material depends on the type of product to be pumped, on the working conditions, on the temperatures, pressures etc.

8.1 "T00" SEAL

Called a CHEVRON seal, it consists of a number of wedge-shaped rings enclosed between the base ring and the top ring made of PTFE. Screw down the pressure ring to obtain the pressure needed to seal the rings against the shaft.

WARNING WHEN FIRST STARTING, ADJUST THE PRESSURE RING TO OBTAIN OPTIMAL CONDITIONS.

If, during operation, there is a leakage of liquid, stop the pump in order to check the tightening of the nut, and, in case, provide with the nut registration. If it is too tight, it can slow down the operation of the pump and lead to overheating and rapid wear of the rings and the shaft.

WARNING DO NOT OVERTIGHTEN THE SEAL.



8.2 "T12"/"T40" SEALS (not available for PA 20A-PA 30A pumps)

They consist of a scraping ring and a guide bush made of PTFE with 2 O-rings (NBR or FPM). They differ in the type of materials. They have pre-established tolerances and do not require any adjustments.

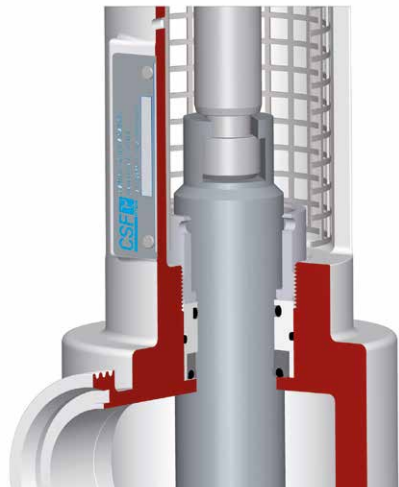
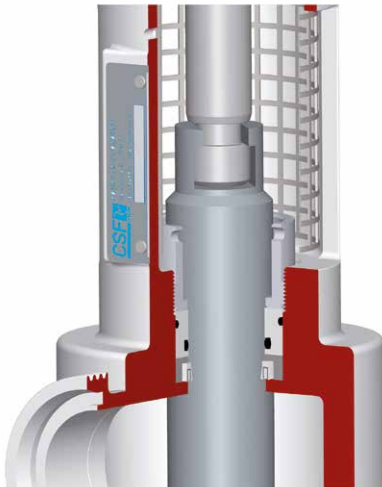

8.3 "T13"/"T42" SEALS (not available for PA 20A-PA 30A pumps)

Scraping ring coupled with a CHEVRON seal made of PTFE, which not only guides the rod but is also adjustable and can be adjusted periodically by means of the securing ring nut. They differ in the different types of material of the scraping ring.

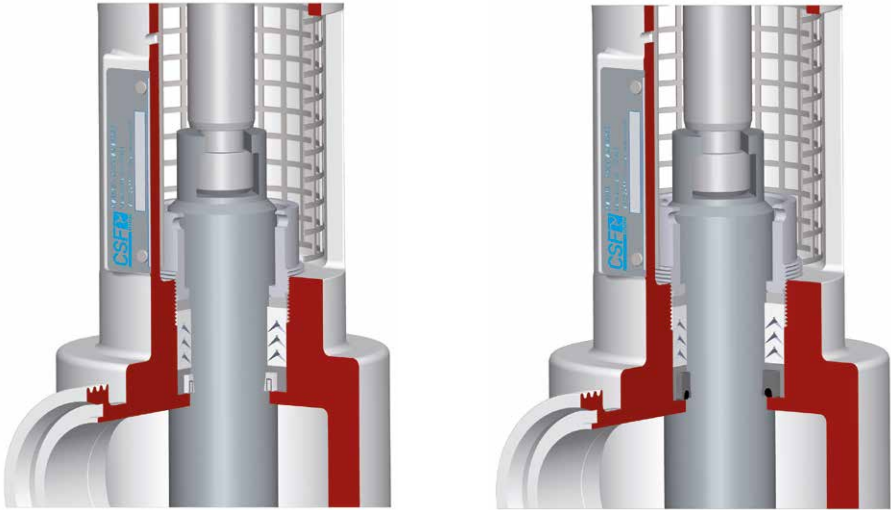

8.4 "T10" SEAL

"T10" seals consist of a lip ring and two O-rings (NBR or FPM) enclosed in the seats of the guide bush made of PTFE. Adherence of the rings to both the rod and the sealing chamber are defined by the processing tolerances and therefore no adjustment is needed.



8.5 "T50" SEAL (not available for PA 20A-PA 30A pumps)
 Simplified solution, easy to clean, made up of a guide clamp for the rod and a Hi-Clean energised ring.



T00



T12



T13

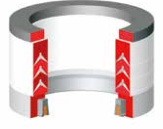

T10



T40



T42



T50

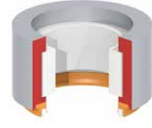

9 INSTALLATION AND STARTING

9.1 INSTALLATION

In the short version, PA 50AM ÷ 100AM pumps can be fitted on the special fixed or wheel-mounted tripod, connecting the suction port to the flexible priming hose submerged in the product, which should be as short as possible.

In alternative, brackets or clamps are available for blocking the pump on the edge of the tank or container to be emptied or to the wall. The long version is submerged in the barrel or tank to be emptied and is to be kept in the vertical position by a suitably sized fixed or wheel-mounted column (art. 54). The vertical sliding movement of the lifting system makes it easy to change the container to be emptied. Other customised applications are available based on the type of installation requested.



Vertical trolley with long pump for drum emptying.



Short version with wheel-mounted tripod

Art. 51
Double clamp to fix the pumps on tanks or containers edge.



Short air-operated piston pump with scraping plate to empty barrels or cylindrical tanks. For high viscosity products.



Art. 55
Wall brackets for fixing pumps to the wall.



9.2 CONNECTING TO THE COMPRESSED AIR SUPPLY

Note: You are recommended always to equip the compressed air system with a drier.

Connect the air supply to the pneumatic motor using a hose with diameter no smaller than the inlet hole (1/2" or 3/4").

If the air is not lubricated, install an oil nebulizer filter unit between the pump and the air supply to guarantee the durability of the seals of the motor unit. The lubrication oil in the nebulizer must be suitable for pneumatic cylinders, it should be extremely fluid (density about 10 SAE) and in compliance with regulations regarding accidental contact with food (e.g. approved in accordance with NSF H1 certification). The quantity of oil to be supplied is roughly one or two drops per minute.

For air motors with shroud, the air discharge silencer filters are fitted both on the shroud and on the air motor head.

It can come with a nebulizer-regulator filter unit to lubricate and regulate the air flow (Pict. 1).

WARNING The supply pressure must be between 3 and 8 bar depending on the back pressure.

PAA 45	1/4" Gas
PAA 63	1/4" Gas
PAA 80	1/4" Gas
PAA 200	1/2" Gas
PAA 230	1/2" Gas
PAA 250-255	1/2" Gas
PAA 310	3/4" Gas

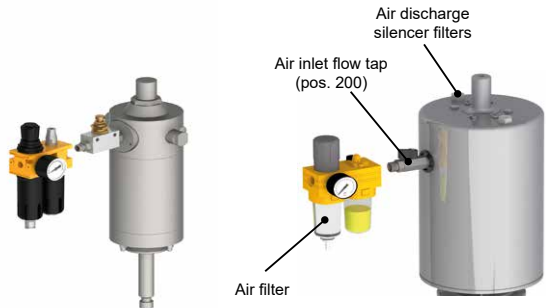

Pict. 1:

PAA 200 ÷ 310 motor

9.3 HYDRAULIC CONNECTION

Connect the suction and delivery hoses, installing gaskets in-between, suitable for the type of fitting and the type of product to be pumped. Run the pump briefly to make sure the seal is perfectly efficient. Warning! PA 80-100 pneumatic pumps are capable of developing pressures of up to 50 bar, consequently you must use suitably sized delivery hoses.

9.4 FLOW ADJUSTMENT

Use the flow tap (200) to adjust the flow rate of the pump, closing the air supply to a certain degree. This changes the number of pumping cycles and consequently varies the flow rate.

Since this is a piston pump, the product flow pulsates. If necessary it can be linearized by using an air-cushion damper on the discharge (art.52).

The discharge pipe can be throttled using a control valve and can even be closed completely. In this case the pump will be in a state of equilibrium and hence stop.



Art. 52

Bag control linear flow outlet product.

10 MAINTENANCE AND INSPECTION

- 1) Drain the water frequently from the filter separator to prevent water from entering the motor cylinder chamber, as it would freeze due to the frequent compression and expansion cycles during operation locking the pneumatic motor.
- 2) Avoid immersing the drive head in solvents since air could enter and enable the solvent to dissolve the synthetic rubber parts of the motor piston and the O-rings.

10.1 IMPORTANT!

Periodically check the integrity of the components during the washing, emptying and internal cleaning of the pump phases. The piston and valves have parts that can wear and deteriorate over time. It is important to check the state of wear beforehand and replace them if necessary, in order to prevent any debris from entering into circulation and contaminating the product.

10.2 EXTENDED STOP

When stopping the pump for a longer time, empty the pump completely and wash it accurately in order to avoid the formation of scales and/or encrustations. When starting the pump again, please follow the above-mentioned instructions.

10.3 CLEANING THE PUMP

Wash the pump carefully after pumping particularly viscous or corrosive products in order to prevent vital parts from locking.

1) If the pump can be managed manually:

- Push the bottom valve inside the suction port, using your finger, to drain the lower section of the cylinder.
- Turn the pump upside down and drain the remaining product through the delivery port.
- Put the pump in a container with washing liquid and operate it so that the liquid runs through it a number of times, until you are sure the pump is clean.

2) If the pump cannot be managed manually:

- Prepare a compatible washing liquid
- Arrange it where the pump can pump it, in a dedicated container or using alternative pipes.
- Activate the pump, creating a re-circulation of liquid, until all the leftover product has been discharged.
- Run a final rinse cycle.

3) The pumping element can be opened quite simply and quickly to inspect inside the pump and to clean it thoroughly.

- Separate the suction port from the cylinder (146).
- Unscrew and remove the cylinder clamp (176).
- Slide the cylinder out (136), revealing the pumping piston and the bottom part of the delivery sleeve.

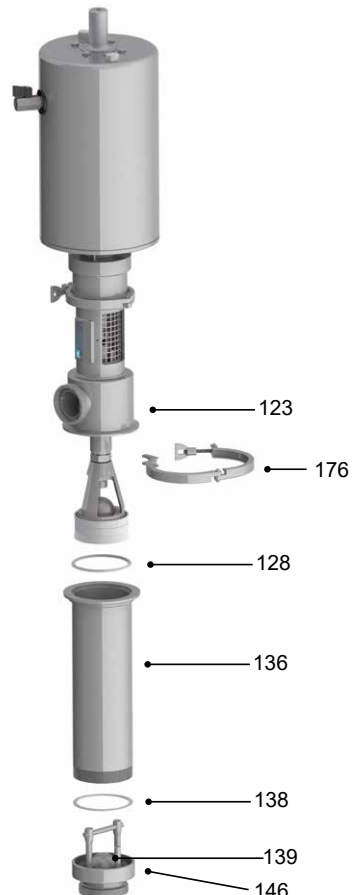

11 DISASSEMBLY

If you have to carry out work on the pump, close the compressed air inlet tap and disconnect the supply pipe to the motor.

(If the pump has seized, due to products pumped previously that have solidified, pour a suitable liquid to dissolve the product pumped through the filling port, shake the pump back and fore and wait for the solvent to start working)

11.1 DISASSEMBLING THE MOTOR

- Unscrew and remove the quick-release clamp (170)
- Hold the pump still, pull the motor and move it sideways to release the bayonet connection.
- Slide the motor out.

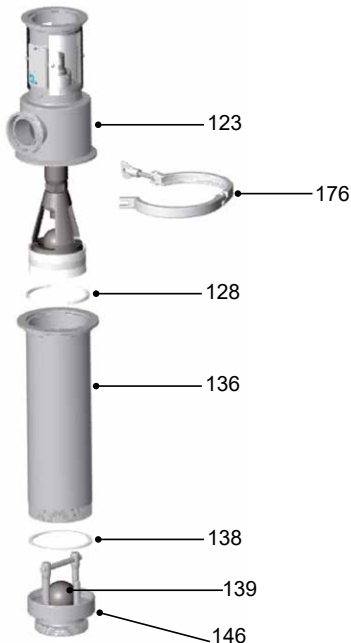
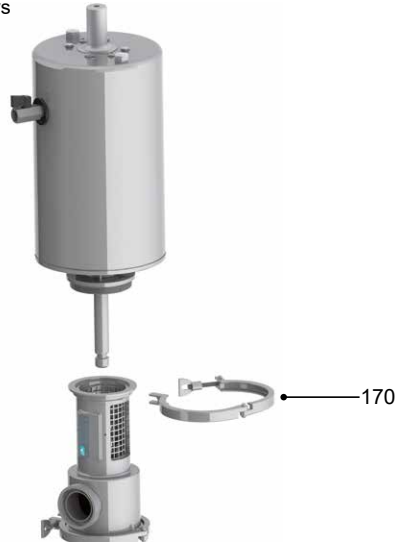
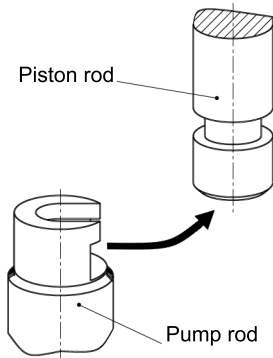

11.2 DISASSEMBLING THE PUMP

WARNING – FOREWORD

When working on the pump, use suitable tools so as not to ruin its surfaces, especially the inner parts

- Unscrew and remove the suction port (146) with the gasket (138), slide the blocking pin out (137) to free the ball (139). Loosen the butterfly nut and open the clamp (176). Slide the cylinder out (136) with the gasket (128).

Take the screws out (198), remove the guards (199), loosen the seal pressing ring nut (125) and slide out the rod-piston axle (122).

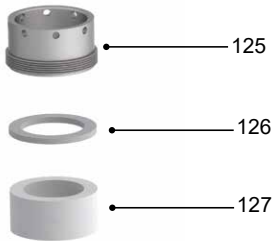
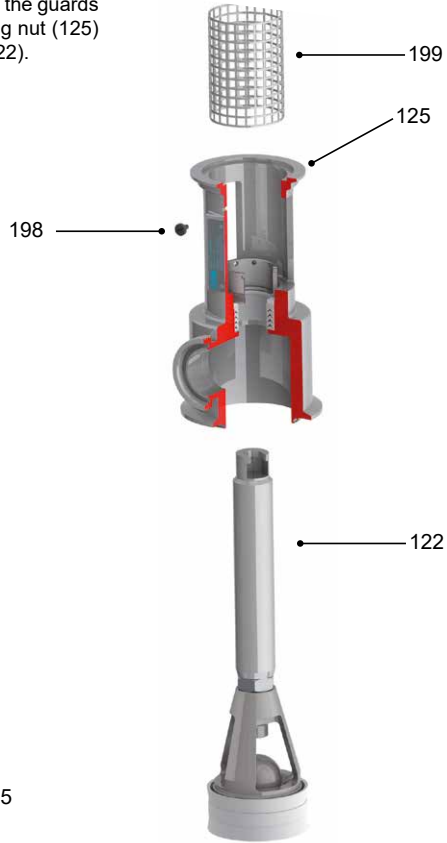

Remove the seal pressing ring nut (125) and slide out the sleeve (123), the seal pressing ring (126) and the seal (127) from their seat.

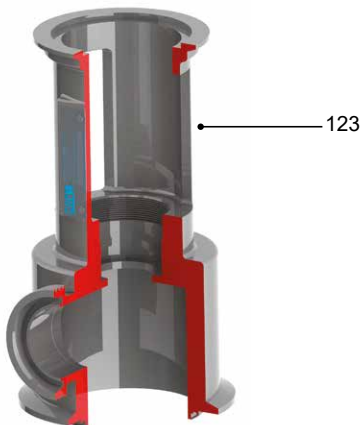

11.3 PISTON DISASSEMBLY

PA 20 ÷ 30

Unscrew the bottom part of the piston (135), slide out the lip rings (134), the piston guide (141) and the ball (132).

Separate the top part of the piston (131) from the connecting rod (124); unscrew the connecting rod (124) from the rod (122).

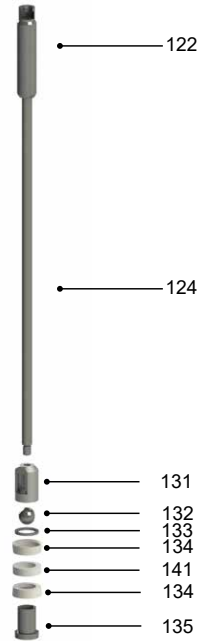

PA 50

Unscrew the bottom part of the piston (135), slide out the lip rings (134), the piston guide (141) and the ball (132).

Unscrew the top part of the piston (131) separating it from the rod (122).

Unscrew the nut (114) separating it from the rod (122).

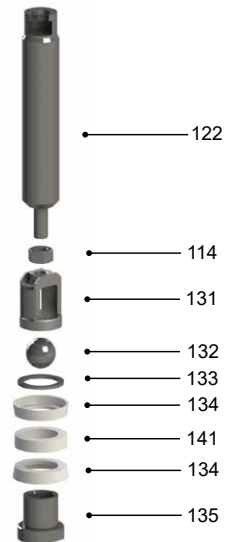

PA 65 ÷ 100

Unscrew the screws (149), remove the washers (209), slide out the bottom part of the piston (135) with the lip rings (134), the piston guide (141) and the ball (132).

Unscrew the top part of the piston (131) separating it from the rod (122).

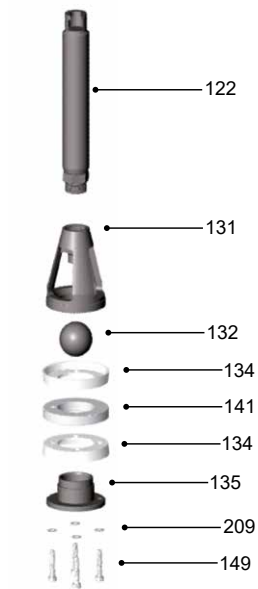

NB: To fit the pump back together, after you have duly inspected it, to restore the parts or to replace any if necessary, follow the instructions just explained in reverse order.

12 WORKING IRREGULARITIES

12.1 THE PUMP DOES NOT START

- 1) Check that there is an adequate air supply to the pneumatic motor.
- 2) Check that the air flow regulator at the inlet is not obstructed, as this would prevent air from being supplied to the motor.
- 3) Check that the pipe has no closed valves and that it is not obstructed by hardened product.
- 4) Check whether the fault is caused by the motor or the pump. (Disconnect the motor and try running it on its own).
- 5) Check the pump (without the motor) if it has locked.

12.2 THE PUMP RECIPROCATES BUT THERE IS NO FLOW

- 1) Short type pump: the flexible suction hose has a hole or is not immersed in the product and the pump sucks air.
- 2) If a filter is fitted on the suction port, it is clogged.
- 3) A foreign body is stuck between the ball (139) and its seat, preventing a perfect seal, therefore you need to remove the obstacle.
- 4) The piston rings (134-141) are worn and the pump is consequently unable to create suction vacuum. Replace them accordingly.

13 DISPOSAL OF THE PUMP

For disposing the pump please observe the following instructions:

- close the compressed air inlet tap and disconnect the supply pipe to the motor; according to technical rules and laws in force.
- disassemble all components of the pump for separate dismantling; wash the components and clean the structure accurately.

The main components of the pump are made from the following materials:

- Pump casing, cylinder, rod, tie rod, piston S.S. - Aisi 316
- Elastomers, gaskets NBR - EPDM - FLUOROCARBON (FPM) - TEFLON - H-ECOPUR
- Motor Aluminium

Components made from amianthus or lead are not used in our production.

WARNING The components of the pump should be properly got rid, according to the corresponding rules in force in receiver's country.



Distributed in the UK by.....

Pump Engineering Limited. Unit B1, Riverside Industrial Estate,

Littlehampton, West Sussex, BN17 5DF, United Kingdom

Tel: 01903 730900 - Fax 01903 730234

email: sales@pumpeng.co.uk Web: www.pumpeng.co.uk

All the instructions, data and representations (in whatever way executed) listed in this publication are indicative and do not binding. C.S.F. does not stand surety or undertake any obligation for the utilisation of this document and for the information contained. In particular, it does not guarantee against omissions or errors of the data and drawings here indicated. Notice that the technical specifications, information and representations in this document are merely indicative and approximate. C.S.F. INOX reserves the right at any moment and without notice to modify the data, drawings and information indicated in this document. C.S.F. INOX guarantees its own products according to the general guarantee conditions in compliance with the required modes of utilisations as per separate documents, regardless of what is indicated in this document, if the assembly and operating methods of the products are observed. Only the instructions indicated in the contract documents, if duly undersigned by authorised C.S.F. INOX personnel, are binding for C.S.F. INOX.